

INFINITY N56kWi internal water heater

Polypropylene (PP) concentric flue installation guide

Rinnai

Important

Rinnai INFINITY gas hot water heater flueing shall be installed in accordance with:

- Manufacturer's installation instructions
- Current AS/NZS 3000, AS/NZS 3500, AS/NZS 5601.1 and G12/AS1

For use with Natural Gas or Universal LPG as indicated on the appliance.

Appliance must be installed, commissioned and serviced by an authorised person, being in New Zealand a licensed gasfitter.

Warning

Improper installation, adjustment, alteration, service and maintenance can cause property damage, personal injury or loss of life.

For more information about buying, using, and servicing of Rinnai appliances call: 0800 RINNAI (0800 746 624).

Rinnai New Zealand Limited
105 Pavilion Drive, Mangere, Auckland
PO Box 53177, Auckland Airport, Auckland 2150

Phone: (09) 257-3800
Fax: (09) 257-3899
Email: info@rinnai.co.nz
Web: rinnai.co.nz
[youtube.com/rinnainz](https://www.youtube.com/rinnainz)
[facebook.com/rinnainz](https://www.facebook.com/rinnainz)

Contents

Flueing options	4
Flueing guidelines.....	5
Flue spigot dimensions.....	6
Joint connection.....	6
Appliance connection	6
Condensate	6
UV protectors.....	7
Cutting to size.....	7
Direct flueing using the FFP100HKIT	8
Vertical and combination flueing.....	8
Flue kits and components.....	10

Important

These instructions are to be used in conjunction with the N-Series installation guide, which contains important information about draining condensate.

For assembly of flue components only use the Centrocerin lubricant provided, or water. Centrocerin is a water soluble lubricant designed to ease assembly of flue components. Other lubricants are not suitable as they will damage the flue. Centrocerin is provided with the vertical roof cowl, and the horizontal thru-wall kit. It is also available for purchase as a separate item.

Flueing options

Polypropylene concentric flueing is for the N56kWi internal unit only. It has a plastic inner pipe to discharge products of combustion and a plastic outer pipe for air supply to the appliance.

Each Rinnai INFINITY N56kWi water heater is flued individually, refer flueing options below.

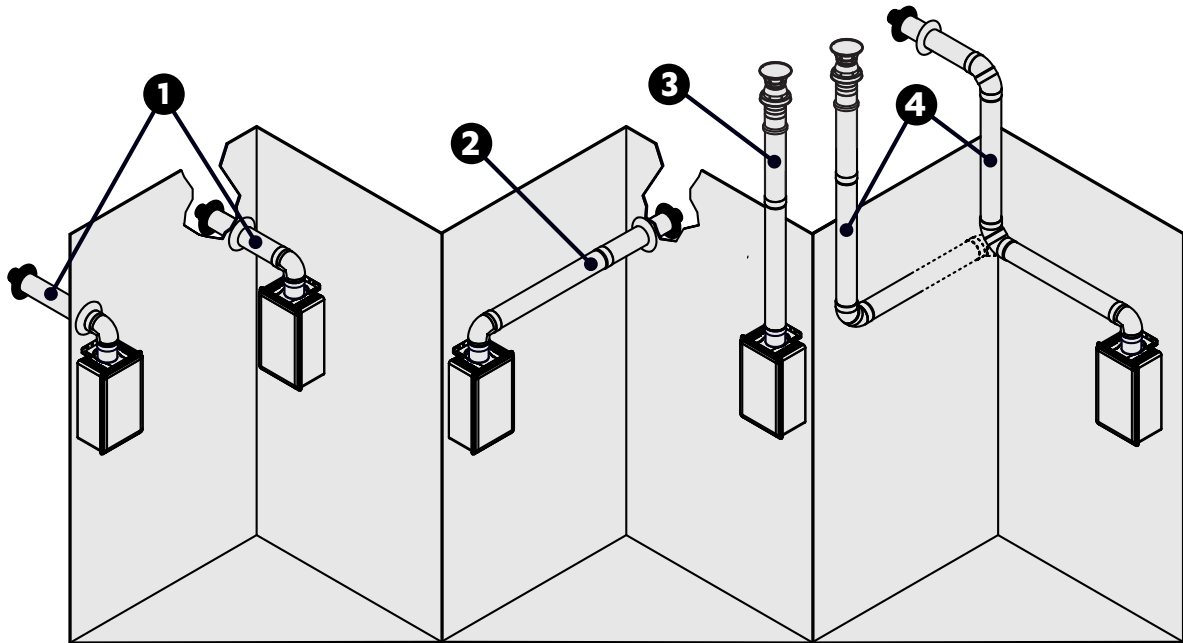

- 1 Direct flueing**
For direct flue installations through an external wall using the direct horizontal flue kit FFP100HKIT—maximum wall thickness 550 mm.
- 2 Horizontal extension flueing**
For flue installations through an external wall using the direct horizontal flue kit FFP100HKIT and additional lengths of pipe FFP100PIPE.

Please note:

Slope horizontal flues back towards the water heater at a 25 mm fall per metre to drain condensate.

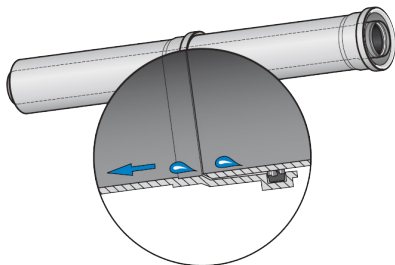

- 3 Vertical straight flueing**
Installations where the internal unit is flued vertically through the roof.
- 4 Combination flueing**
Installations using a combination of horizontal and vertical flueing.

Flueing guidelines

The flue terminal is to terminate in a location so as not to cause a nuisance, in accordance with AS/NZS 5601.

Multiple flues

Ensure minimum distances, as shown below, are maintained.

Each terminal is to be terminated at the same height, refer images below—please note these images show older style terminals, which have since been updated.

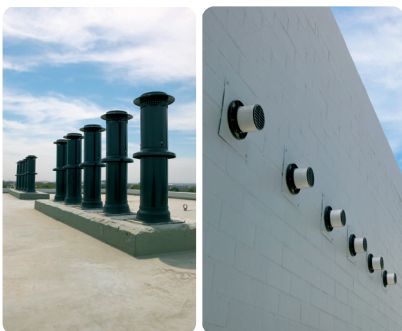
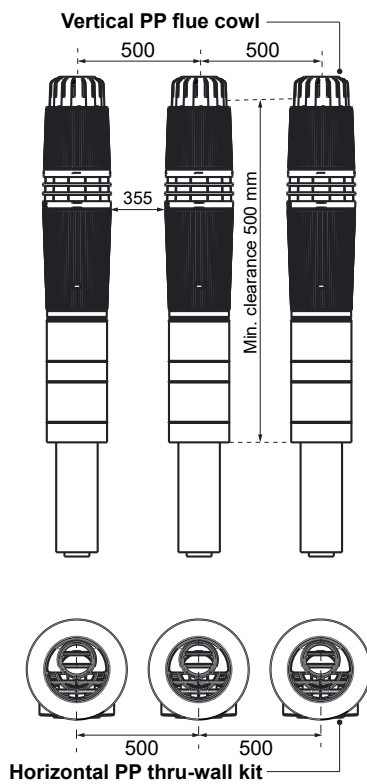

Older style roof cowls and horizontal terminals all terminating at the same height

Flue support

Ensure the flue is supported independently of the appliance by use of suitable clips or brackets in accordance with AS/NZS 5601. Appropriate standoff brackets are supplied with each roof cowl and flue pipe.

Flue length

The chart below highlights the maximum flue length and number of bends. One 90° bend equates to 3 m, and one 45° bend equates to 1.1 m.

If you need to extend beyond 20 m please contact Rinnai as we have another flueing option available.

		Number of 90 ° Bends				
		0	1	2	3	4
Flue Length (m)	1					
	2					
	3					
	4					
	5					
	6					
	7					
	8					
	9					
	11					
	12					
	14					
	15					
	17					
	18					
	20					

Flueing table showing maximum flue length and maximum number of bends

Vertical terminations

To ensure products of combustion are cleared, adequate clearance from the building is required. The vertical flue cowl should have a 500 mm clearance from any part of the building. This also applies to steeped and pitched roofs, where the flue cowl should be 500 mm clear of the ridge line. An adequate flow of fresh air must exist around the flue cowl following installation.

Minimum clearances are shown in AS/NZS 5601.1.

White pipe UV protection

Where appropriate, all components must be protected from UV. The horizontal terminal (black section) is UV resistant. The vertical terminal is provided with two black UV protectors. Anything else exposed to UV should be painted.

Flue spigot dimensions

The Rinnai INFINITY flue spigot for the N56kWi is fixed and cannot be adjusted.

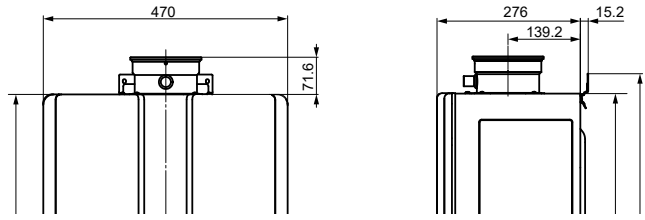

Joint connection

Flue connections must be firmly pressed together so that the gaskets form an airtight seal.

To ensure optimum joint connection it is recommended to secure with 4 x 12.5 mm (#8 x 1/2") self tapping screws.

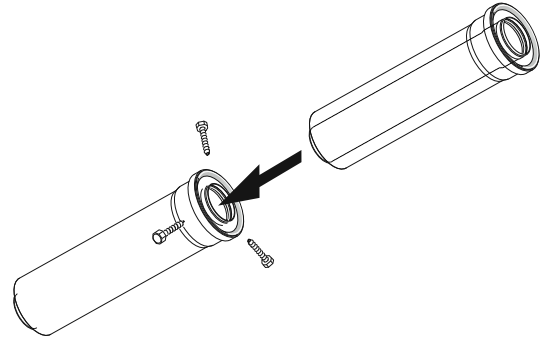

Appliance connection

All N56kWi flueing will start with either the horizontal adapter (part of the horizontal thru wall kit) or the vertical adapter. This reduces the flue diameter from Ø80/120 mm to Ø60/100 mm.

Insert the male end of the adapter into the female flue spigot on the top of the water heater. Secure in place with self tapping screws.

Vertical starter adapter

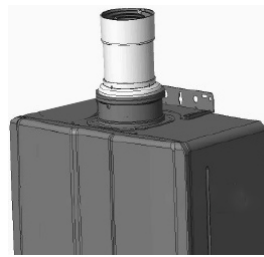

Horizontal starter adapter

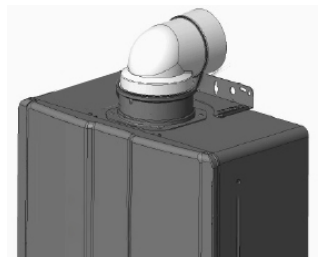

Condensate

The condensate trap collects any condensate from the flue and prevents condensate from entering the water heater and causing damage.

Condensate is a by-product of gas combustion and is mildly acidic. For this reason copper tube and fittings must not be used as it will corrode. Instead Rinnai recommends plastic pipe and fittings such as UPVC or PE.

For further information refer to the Rinnai INFINITY N-Series installation guide.

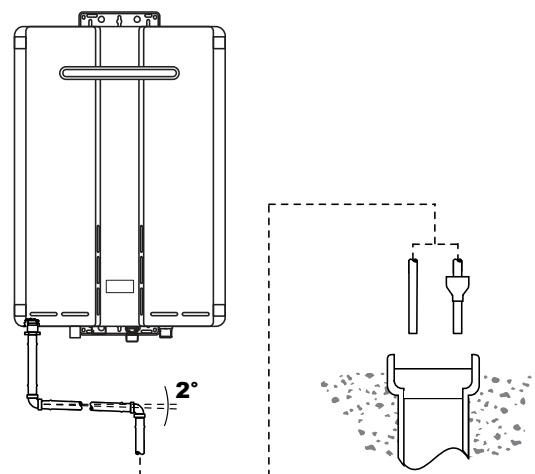

UV flue protectors

The roof cowl comes with two black UV protectors (already joined) for covering and protecting the white pipe from UV damage. If any remaining white pipe is exposed to UV, this should be painted with a suitable UV resistant coating.

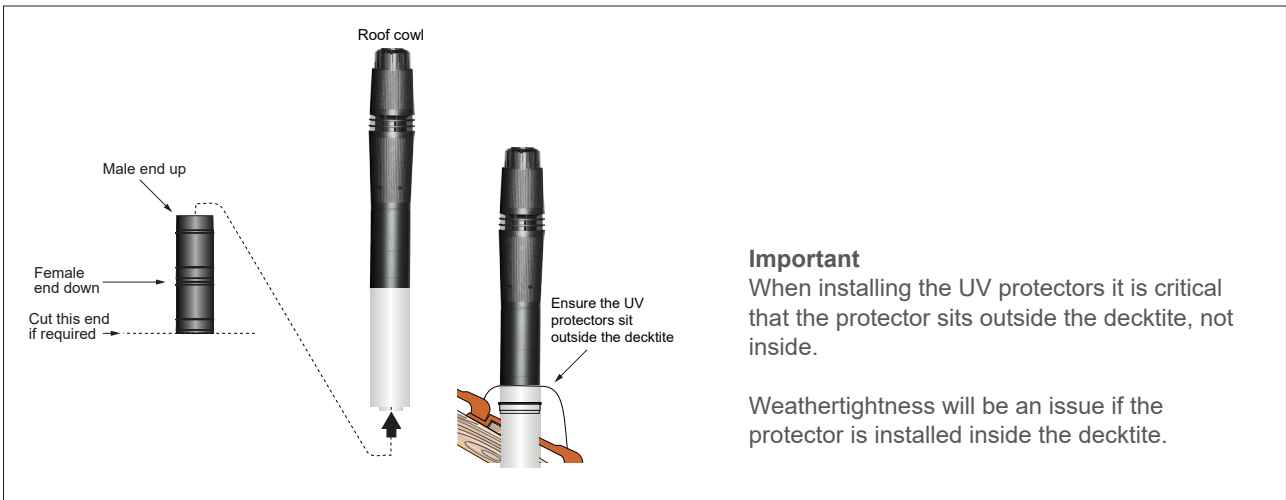

Cutting to size

Pipes overlap by approximately 32 mm. Once joined the effective length is reduced by 32 mm. This needs to be factored when cutting to size, refer image below.

The inner pipe must always extend 10 mm beyond the outer pipe in the male end of the flue. Always cut the male end of the flue and not the female end. Deburr sharp edges as this could damage the gasket resulting in a system that is no longer air-tight.

Roof cowl

The roof cowl can be shortened by cutting both the inside and outside pipes the same length. Always deburr the sharp edges.

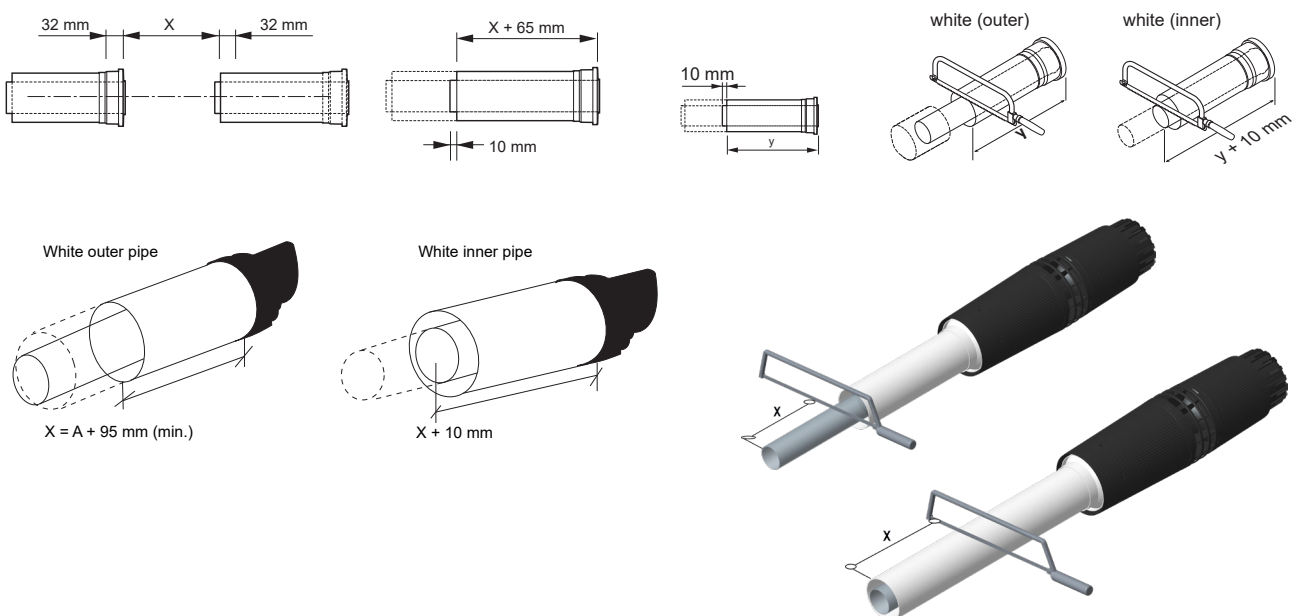

Direct flueing using the FFP100HKIT

For installations where the Rinnai INFINITY is mounted directly on the inside of an external wall with a wall thickness of between 95-550 mm, 95 mm is the minimum length the flue terminal can be cut down to (refer image on previous page). Horizontal flues must slope 25 mm per metre back towards the water heater.

The FFP100HKIT contains:

- Horizontal adaptor (bend)
- Horizontal flue terminal
- Internal white wall plate/seal
- External black wall seal

Installation

1. Mount the water heater in an appropriate location.
2. Using the dimensions provided, mark a point along the appliance centreline approximately 122.6 mm from the top of the water heater. This mark forms the centre for the wall penetration.
3. Make a 115 mm wall penetration for the flue. Ensure the flue spigot of the water heater is covered while cutting to avoid debris entering the flue connection of the appliance.
4. Measure the required length for the horizontal terminal to penetrate the wall.
5. Fit the external wall seal to the terminal pipe. Pass the male end of the terminal pipe through the penetration point and weatherproof the penetration. Fit the internal wall seal.
6. Connect the terminal pipe to the bend, ensuring the components are pushed 'fully-home'. Secure the joints of the bend to the terminal pipe with three self-tapping screws (not supplied).

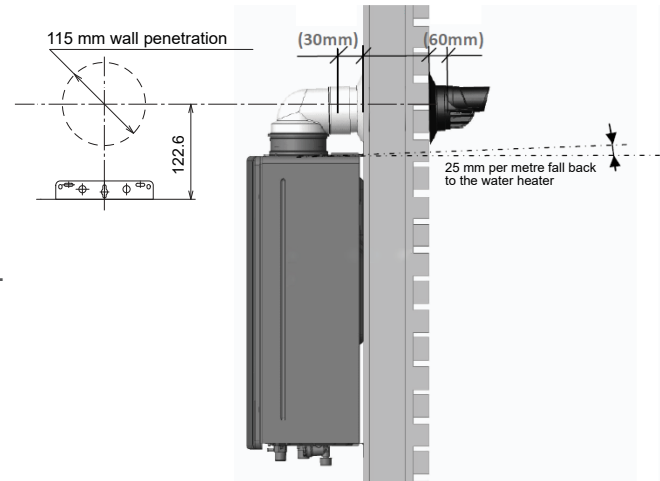
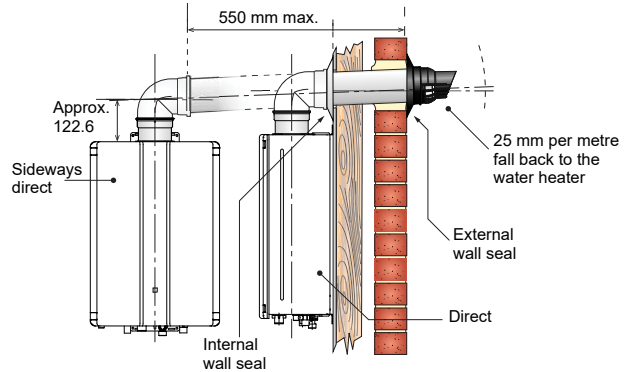

Extended horizontal flue

The extended horizontal flue option can be used when the water heater is mounted against an internal wall and the flueing needs to be extended horizontally for a longer distance to exit an external wall. Use the FFP100HKIT as a starting point and customise with flue pipe.

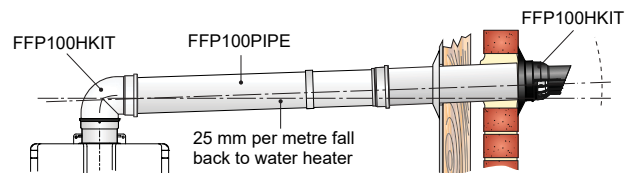

Extended horizontal flue

Remember to allow for a condensate connection. For further information refer to the Rinnai INFINITY installation guide, section 'Condensate'.

Important

The white section of the terminal should not be exposed outdoors. If the terminal protrudes from the wall exposing the white section of the pipe, this can affect performance of the product.

Vertical and combination flueing

If starting horizontally and finishing horizontally, use the FFP100HKIT as a starting point and customise. If starting horizontally and ending vertically or vice versa, individual flue components will need to be ordered. Flueing must start with a horizontal or vertical adapter.

1. Mount the water heater in an appropriate location.
2. Set a plumb bob from the centre of the heater flue outlet to the ceiling marking position. Cut a 115 mm hole in the plasterboard (or a suitable oval for pitched applications). Repeat this step for the underside of the roofing.
3. Install the UV protectors to the vertical terminal.
4. Calculate the required number and combination of FFP100PIPE lengths and cut to size as required.
5. Install decktite roof seal (not supplied).
6. Ensure the flue is fully supported independently of the appliance, by the use of suitable clips or brackets, in accordance with AS/NZS 5601. Appropriate standoff brackets are supplied with each roof cowl and flue pipe component.
7. All joints must be secured with suitable self tapping screws.
8. Install condensate drain.

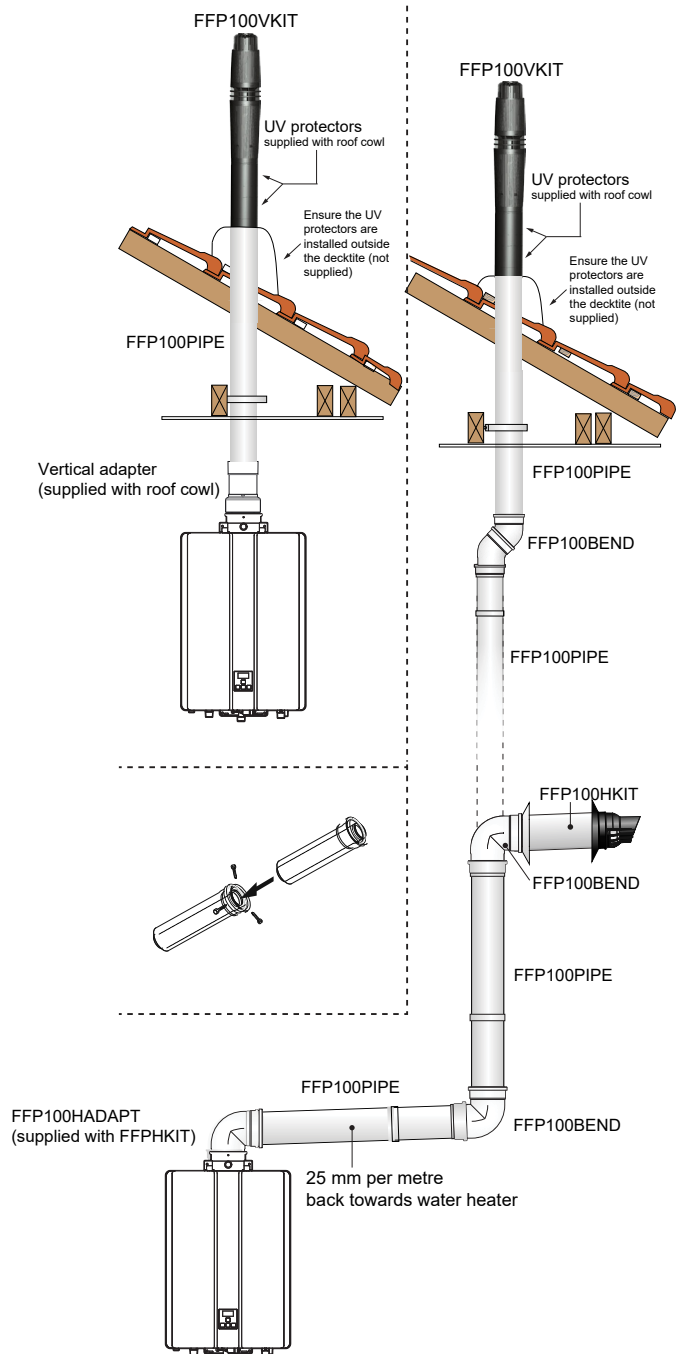

N56kWi polypropylene flue components

All the major flue components are constructed of a polypropylene outer and inner. These have zero clearance to combustibles. All dimensions are in mm.

FFP100VADAPT: Vertical adapter 60/100 (supplied with vertical roof cowl)

Required for all vertical flue applications. The vertical adapter connects into the flue spigot of the N56kWi.

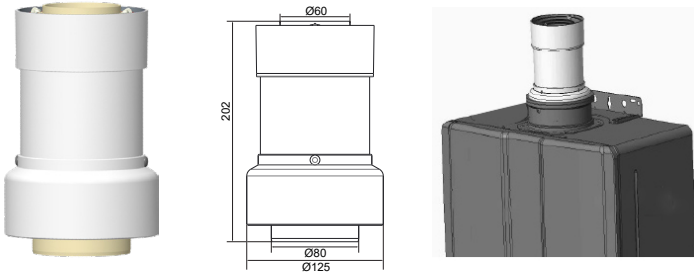

Please note

The vertical adapter is supplied with the vertical roof cowl and does not need to be ordered separately.

FFP100HADAPT: Horizontal adapter 60/100

Required in combination flueing where the flue starts off horizontally. The horizontal adapter connects into the flue spigot of the N56kWi.

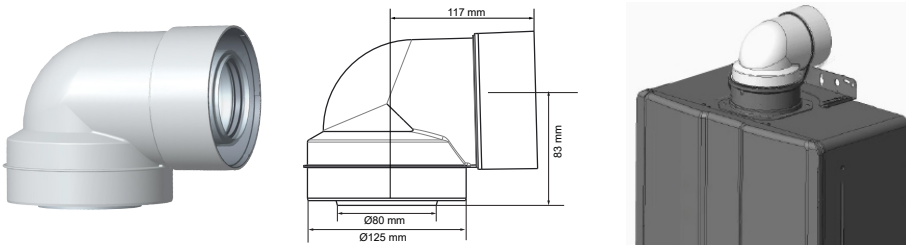

FFP100BEND: Flue bends 45°, sold as a pair

Used for combination flueing for changing direction. One 90° bend equates to 3 m, one 45° bend equates to 1.1 m.

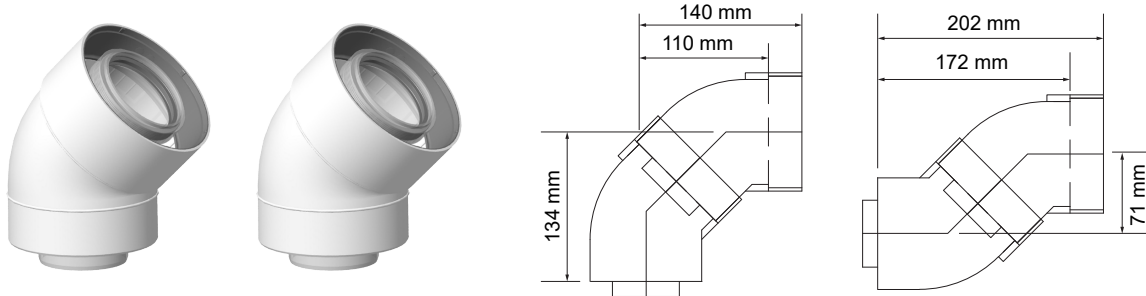

CF790025 Centrocerin lubricant

Water soluble lubricant designed to ease assembly of flue components. Other lubricants are not suitable as they will damage the flue.

Please note:
This comes with the horizontal, and vertical terminal kits.



FFP100BRACKET Flue bracket

Flue clamp support—white. Purchased if additional support is required. Every length of flue should be supported.

Please note:
This comes with each flue pipe.



FFP100PLATE Inside wall plate

Internal white wall plate/seal, used to tidy up any installation work. Comes as part of the FFP100HKIT, but can be ordered separately for other flueing applications. Comes in two pieces, refer next page for dimension information.

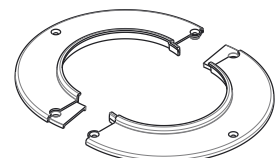

FFP100PIPE: Flue pipe 1000, can be cut to size, includes flue bracket to support flue

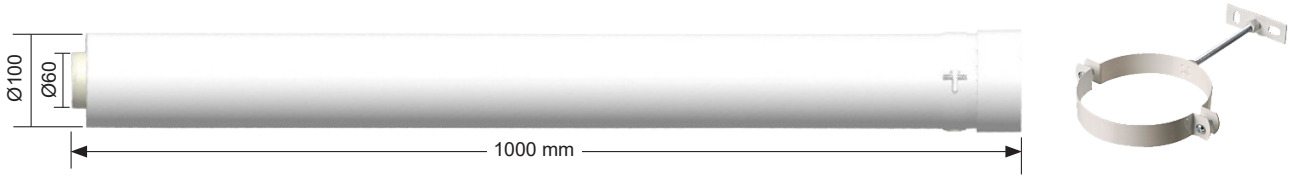

FFP100HKIT: Direct flue kit for horizontal installations, can be cut to size

Includes white and black wall seals and a tube of centrocerin lubricant.



FFP100VKIT: Vertical terminal kit PP 60/100, can be cut to size

Includes:

- roof cowl (FFP100VCOWL)
- vertical flue adapter (FFP100VADAPT)
- UV flue protectors (for covering and protecting the white flue pipe from UV damage)
- flue clamp
- tube of centrocerin lubricant

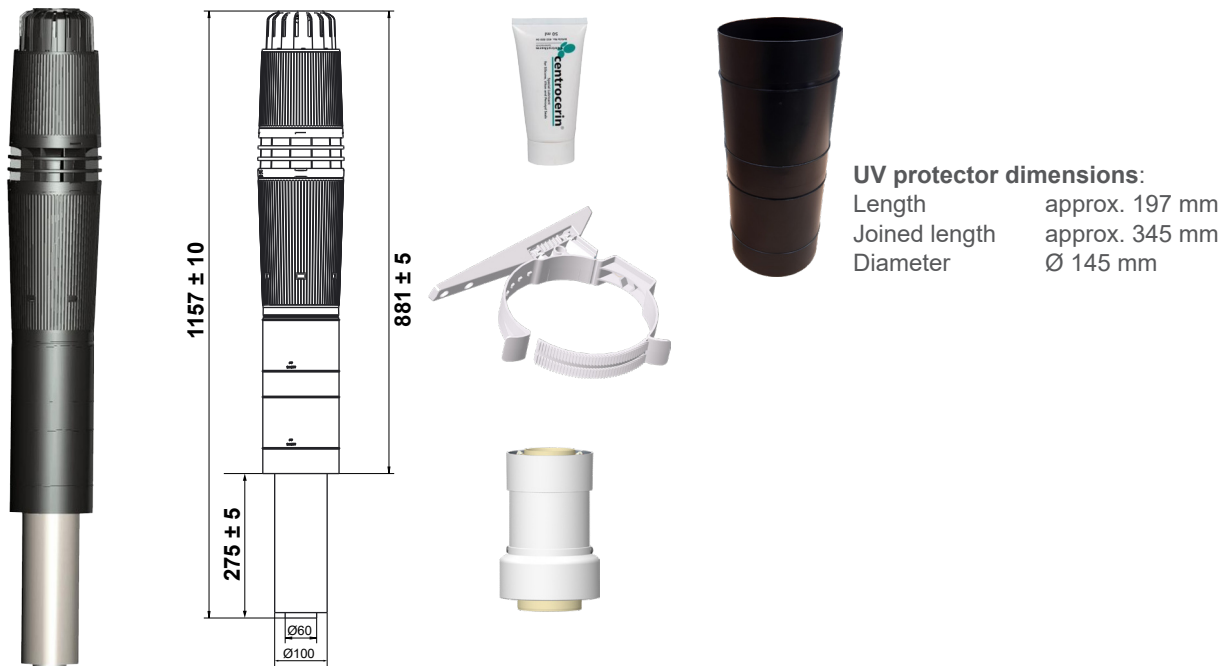

Rinnai.co.nz

Rinnai New Zealand Limited
105 Pavilion Drive
Mangere, Auckland 2022

PO. Box 53177
Auckland Airport
Auckland 2150

Tel: 0800 746 624
<http://www.youtube.com/rinnainz>
<http://facebook.com.rinnainz>

INFINITY N56kWi polypropylene flue installation 12746-B