

GENERAL INFO

STAINLESS STEEL BAG FILTER HOUSING

The Puretec SSBH Series stainless steel bag filter housings offers a variety of solution for your large scale, heavy-duty filtration needs. Simple to install and maintain, these housings are ideal for schools, restaurants, farms, institutions and industrial use.

Unlike cartridge filters or strainers, all the contaminants are captured within the bag and do not pass into a process stream when a bag is replaced.

An economical bag filter can be used to improve the life of more expensive down stream filters and is often placed first in a filter train. Considerable savings can be made for a modest investment.

FEATURES & BENEFITS

- Low cost, high volume nominal filtration.
- 304 & 316 stainless steel non-coded housing as standard polished internally and externally.
- Quick release clamp for simple bag removal from the top of the housing.
- Ideal for the filtration of water, effluent water, recirculation water.
- Pre UV or RO equipment and cooling tower applications.
- Can withstand temperatures up to a maximum of 75°C.



BAG FILTER REPLACEMENTS

Ordering Code:	Description	Size
SSBR011	1 micron	Size 1
SSBR051	5 micron	Size 1
SSBR012	1 micron	Size 2
SSBR052	5 micron	Size 2
SSBR252	25 micron	Size 2

BAG FILTER NOT INCLUDED

For more information, please visit our website puretegroup.com, email us at sales@puretegroup.com or call us at **1300 140 140** (AU) **0800 130 140** (NZ).

TECHNICAL INFORMATION

Ordering Code:	SSBH-1-50-304	SSBH-1-50-316	SSBH-2-50-316	SSBH-2-75-316	SSBH-2-75F-316
Material of Construction:	304 Stainless Steel	316 Stainless Steel	316 Stainless Steel	316 Stainless Steel	316 Stainless Steel
Bag Size:	Size 1	Size 1	Size 2	Size 2	Size 2
Inlet / Outlet Connections:	2" BSPF	2" BSPF	2" BSPF	3" BSPF	3" Flanged
Flow*:	20 m3/hr (340 Lpm)	20 m3/hr (340 Lpm)	45 m3/hr (757 Lpm)	45 m3/hr (757 Lpm)	45 m3/hr (757 Lpm)
Vent Port BSP	1/4"				
Maximum Operating Pressure:	1058 kPa				
Operating Temperature:	4 - 75°C				
Warranty:	1 year^				

*Warranty is 1 year parts and labour, plus 1 year parts only. *Flow rate is dependent on bag filter used. Application should be designed according to bag filter capabilities.

PRODUCT DIMENSIONS Measurements in Millimeters (mm)

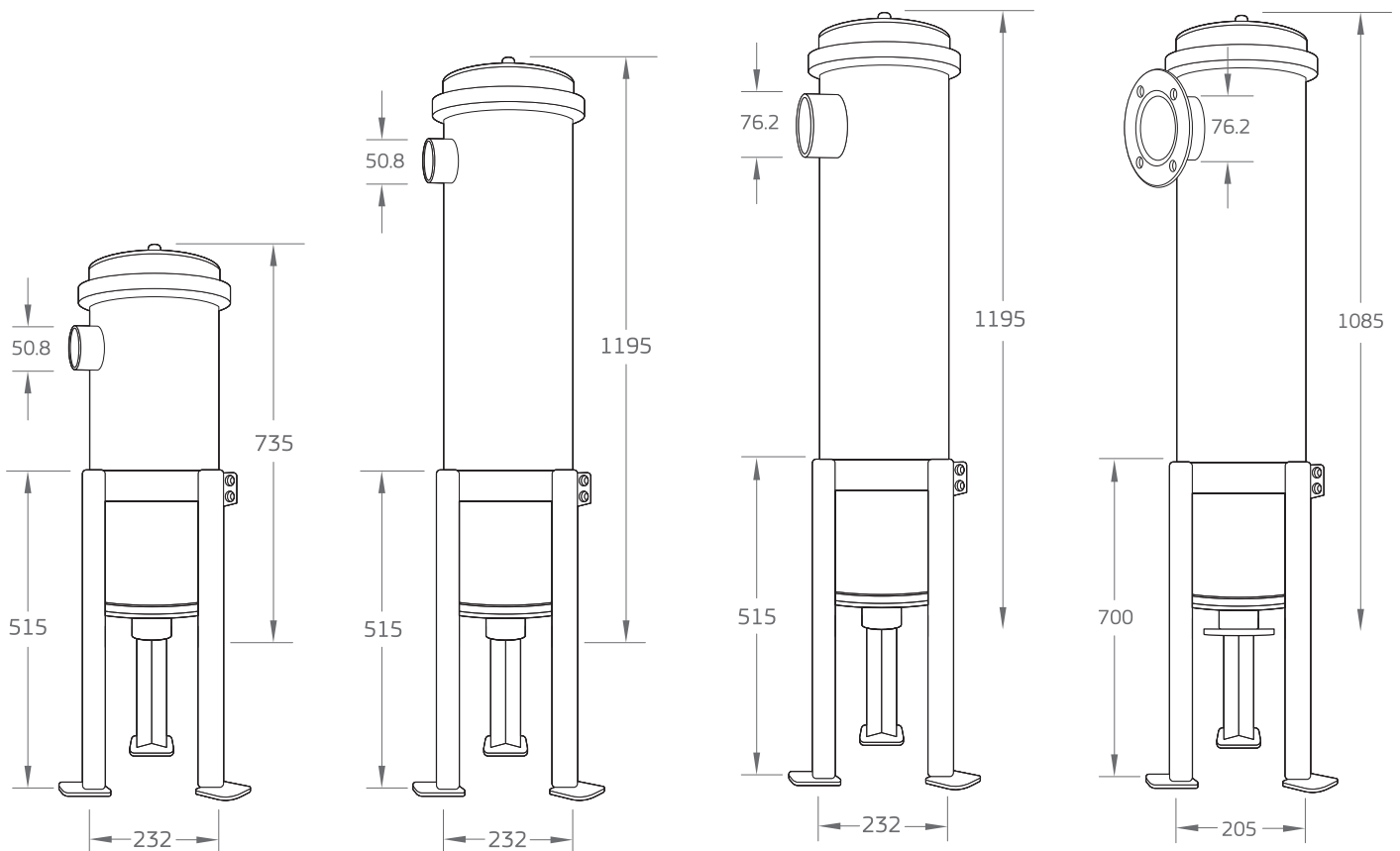

**SSBH-1-50-304
& SSBH-1-50-316**

SSBH-2-50-316

SSBH-2-75-316

SSBH-2-75F-316

Note:

1. No claims can be made based on the specifications and images in this document. The design, technology, colours, features and prices are subject to change.
2. This document and all its contents are copyright protected. All rights are reserved, particularly alteration, translation and reproduction using electronic systems.
3. ^Warranties in this document cover parts for the period stated and include cover for parts and labour for the first year where applicable, subject to approval. Our Water Filtration Specialists can provide you with advice to suit your needs.
4. For warm or hot water applications, we strongly recommend to test the chloride level in the water source & confirm suitability with the Puretec team.