

PROJECT TOILET ROLL HOLDER DOUBLE CHROME

60910.02

\$185

ELEMENTi

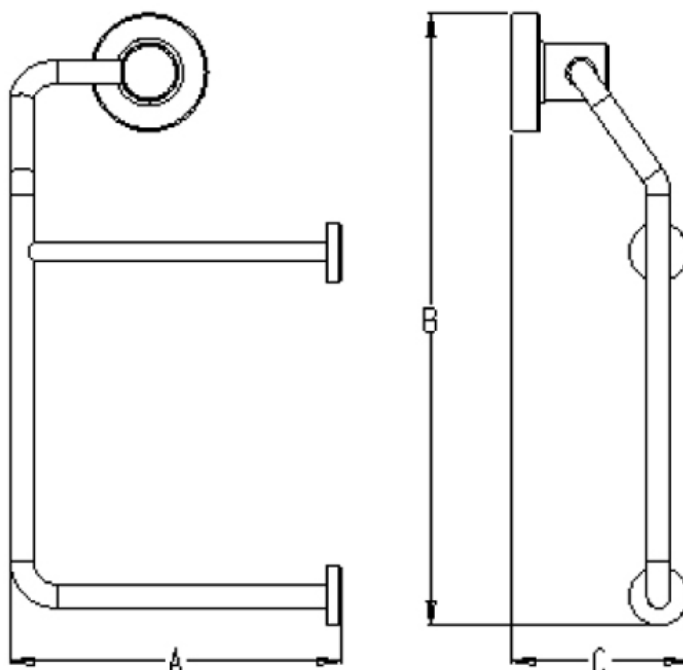

A: 141 mm / 5,55"

B: 210 mm / 8,27"

C: 75 mm / 2,95"



Residential/Light
Commercial

Suitable for Residential/Light Commercial Use (Kitchens, Bathrooms and Laundries in Motels, Hotels and Retirement Villages)

10

Guarantee

10 Year Guarantee



Galvanic Plating
Process

CHROME: Galvanic plating process. Covering with 0,3 – 0,4 microns chrome average. Items are tested as per Norm En 246 with salt spray chamber – 240 hours (equivalent to 6 years)



Galvanic Plating
Process

BRUSHED NICKEL: Galvanic plating process protected with transparent lacquer coating (thickness 40-50 microns) . 120 Hours salt spray tested (equivalent to 2 years resistance)





Made in Spain

Project is a sleek, minimalist styled accessory range that will compliment your new bathroom.